

(54) Title of the invention : REMOVABLE MULTI-ELASTIC MEMBER SUSPENSION STRUT FOR ALL TERRAIN VEHICLES.

(51) International classification :B60G0015060000, G02B0007090000, G03B0013360000, B62D0025080000, B60G0007020000

(86) International Application No :NA
Filing Date :NA

(87) International Publication No : NA

(61) Patent of Addition to Application Number :NA
Filing Date :NA

(62) Divisional to Application Number :NA
Filing Date :NA

(71)Name of Applicant :

1)PANDIT DEENDAYALENERGY UNIVERSITY

Address of Applicant :PANDIT DEENDAYALENERGY UNIVERSITY KNOWLEDGE CORRIDOR, RAISAN VILLAGE, GANDHINAGAR, GUJARAT, INDIA - 382 007 -----

Name of Applicant : NA

Address of Applicant : NA

(72)Name of Inventor :

1)MR.RAHUL DEHARKAR

Address of Applicant :PANDIT DEENDAYALENERGY UNIVERSITY KNOWLEDGE CORRIDOR, RAISAN VILLAGE, GANDHINAGAR, GUJARAT, INDIA - 382 007 -----

2)DR.ANURAG MUDGAL

Address of Applicant :PANDIT DEENDAYALENERGY UNIVERSITY KNOWLEDGE CORRIDOR, RAISAN VILLAGE, GANDHINAGAR, GUJARAT, INDIA - 382 007 -----

3)DR.VIVEK PATEL

Address of Applicant :PANDIT DEENDAYALENERGY UNIVERSITY KNOWLEDGE CORRIDOR, RAISAN VILLAGE, GANDHINAGAR, GUJARAT, INDIA - 382 007 -----

(57) Abstract :

Suspension is the most important component for off-road vehicles (All Terrain Vehicles). Off-road vehicles have to undergo heavy loads as well as very high bump impacts. They even require adequate rebound for better ground contact and to avoid failure of spring system. Conventional method of using single/normal springs in suspension struts for suspension system in off-road vehicles have high probability of failure while heavy bump impacts resulting in buckling of springs or losses in rebound characteristics. Instead of using the conventional single spring suspension strut, using customized concentric springs suspension strut could level up the performance of the vehicle suspension. The invention uses replaceable concentric spring mechanism that could open room for changing and trying different combinations of springs and to ensure the performance and ride of suspension system based on given conditions. This mechanism would also open room for controlling the travel of the spring and rebound characteristics.

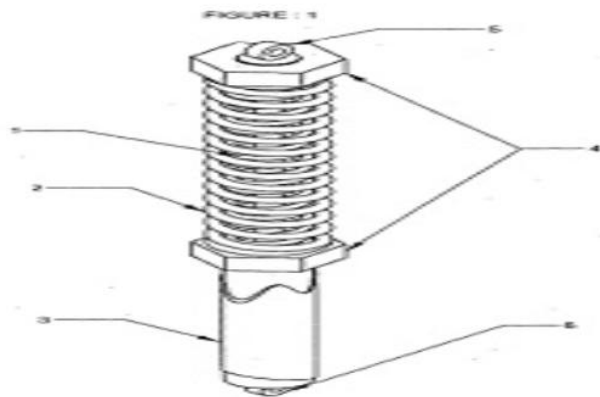

No. of Pages : 6 No. of Claims : 6